

BROAN®

Model: HV 1.5

Part no. HV15

160 cfm (including 30 cfm of air exchange)
to 185 cfm (including 55 cfm of air exchange)

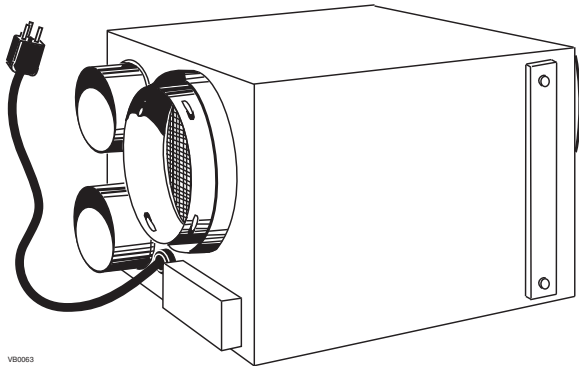

VB0063

AN AFFORDABLE SOLUTION FOR HOUSES WITH EXCESS HUMIDITY PROBLEM.

The Broan HV 1.5 is the cost-effective air exchange unit. It is the minimal requirement for improved Indoor Air Quality, continuous air exchange and excess humidity control.

- The diameter of intake and exhaust ports for indoor air are 6" (15 cm), to facilitate the installation in a new house
- 5" (12 cm) diameter adapters (included) for intake and exhaust ports outdoor air if needed for a retrofit application
- Plug-in module, simplifying the installation
- Installation kit including our exclusive Tandem® transition* and the dual outside port*, for a one outdoor connection (Kit part no. 15273)
- CMR low voltage wall control (included), allowing air recirculation
- User friendly and easy maintenance
- Quick installation for houses up to 2,000 sq. ft.**
- Mechanical air filtration by a washable mesh filter
- Can be installed in the attic

*Patented.

**For new constructions, please refer to your local building code.

The HV 1.5 air exchanger controls excess humidity in the house, thus reducing risk of condensation in windows. The installation for this ventilation system is quick and easy for all types of houses.

Available at:

WHOLE-HOUSE AIR EXCHANGER

Control

- The HV 1.5 air exchanger is ready to receive CMR wall control (included in the box)
- This wall control offers 3 operating modes: Minimum, Maximum and Recirculation
- The Fresh air indicator lights up when the unit is on Minimum or Maximum mode
- Also, it is equipped with a Maintenance indicator, telling you when it is time to perform the filter maintenance



VC0114

Air flow during exchange

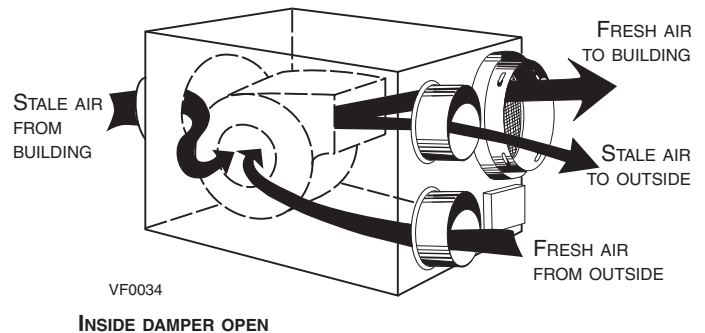

Warranty

The Broan HV 1.5 is fully protected by a 2-year warranty on all parts and labor in workshop only.

Requirement and Standard

- Complies with the CSA C22.2 no. 113 Standard applicable to ventilators
- Complies with UL 507 Standard

Dimensions and Clearances: Broan HV 1.5

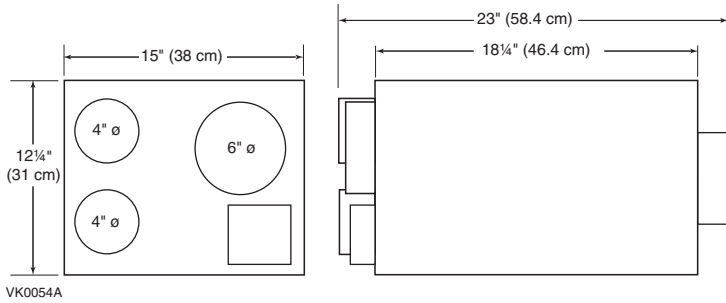

Attic Installation*

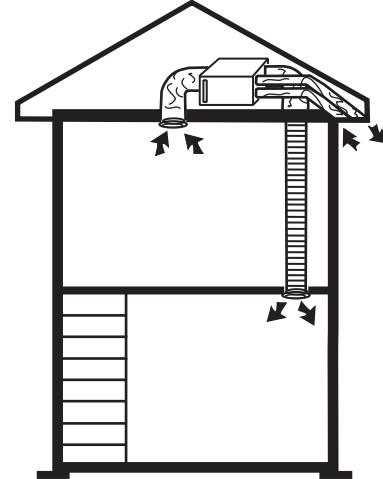

VH0004

*If the HV 1.5 is installed in the attic, the unit must always be in operation during cold season. Use the installation kit no. EA20130.

Basement Installation

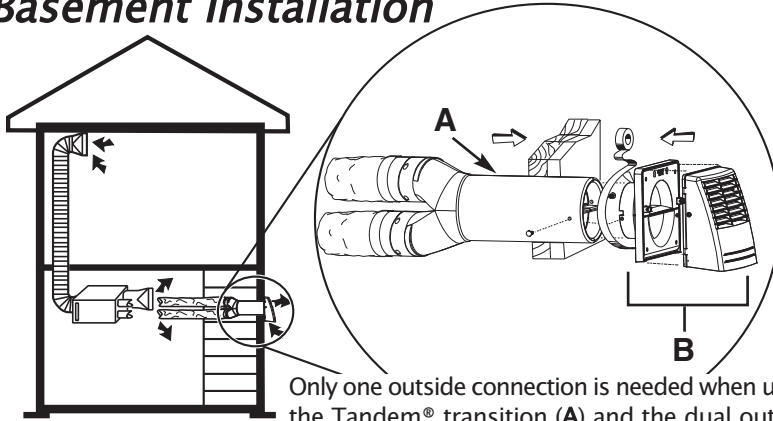

VH0052

Only one outside connection is needed when using the Tandem® transition (A) and the dual outside port (B) simplifying the installation. (Both A and B included in kit no. 15273.)

Ventilation Performances

EXT. STATIC PRESSURE	NET VENTILATION AIR FLOW		GROSS AIR FLOW RECIRCULATION		POWER	
	Pa	in. w.g.	l/s	cfm	l/s	cfm
50	0.2	26	56	104	220	139
100	0.4	17	35	88	187	135

NOTE: All specifications are subjected to change without notice.

Specifications and rating

- Model: HV 1.5
- Part number: HV15
- Total assembled weight: 40 lb (18 kg)
- Supply air duct connections:
 - stale: 4" or 5" (10 cm or 12 cm)
 - fresh: 6" (15.25 cm)

- Exhaust air duct connections:
 - stale: 6" (15.25 cm)
 - fresh: 4" or 5" (10 cm or 12 cm)
- Filter: 1 mesh filter
- Housing: pre-painted steel
- Dimensions: 23" x 12 1/4" x 15" (58.4 cm x 31 cm x 38 cm)

- Mounting: Suspension by chains and springs
- Control modes: Minimum, Maximum and Recirculation
- Unit electrical characteristics:
 - Voltage: 120 volts
 - Power: 140 watts
 - Current: 1.2 amperes

Submitted by:		Date:	Project:
Quantity:	Model no.:	Remarks:	Location:
			Architect:
			Engineer:
			Contractor:



BROAN

Residential Product Group, 550 Lemire Blvd., Drummondville, QC, Canada J2C 7W9 - Tel.: 1-800-567-3855 Fax: 1-800-567-1715



www.broan.ca

10/05

PRODUCT SHEET NO. 90968