



RANGE HOODS

BROAN ESB10 SERIES RANGE HOOD

Part numbers: ESB1030WH, ESB1030BL and ESB1030SS

280 CFM

0.9 sone at 100 CFM

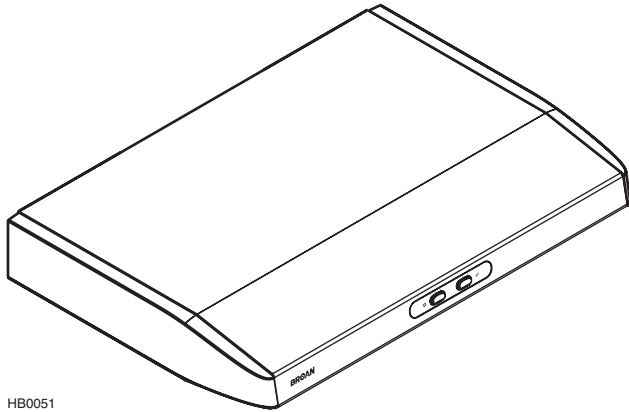

HB0051

The brand new Broan ESB10 Series range hoods are ENERGY STAR® qualified. This means that more than being among the slimmest, most elegant hoods on the market, they are energy efficient. Who said you can't always get what you want?

- Mechanical control
- 2 ventilation speeds
- Fluorescent lighting
- Full size micromesh filters

WARRANTY

Broan-NuTone Canada warrants to the original consumer purchaser of its products that such products will be free from defects in material or workmanship for a period of one (1) year from the date of original purchase.

AVAILABLE AT:

BLOWER

- Our motor is enveloped in acoustic insulation. This means that the noise level of the ESB10 Series range hood is less than 1 sone at normal speed. This range hood is among the quietest in its category.

FILTERS

- Dishwasher-safe, full size micromesh filters - provide a better grease catching capacity and a stylish finish under the hood.

CONTROL



HC0031

Easy-to-use rocker switch control.

- Two ventilation speeds: quiet operation (1) or high performance (2).
- Bright cooktop lighting provided by 2 fluorescent lamps (included). Press either on left side (1) or right side (1) to obtain full lighting. To shut off the lights, set the rocker switch on central position (0).

OPTIONS

- Available in 30" width.
- Offered in three popular appliance colors: White, Black and Stainless Steel.

MAINTENANCE

- The blower wheel and the inlet ring can easily be removed without tool.

- The blower wheel, the inlet ring and the micromesh filters are dishwasher-safe.

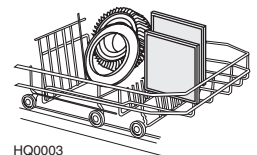

HQ0003

REQUIREMENTS AND STANDARDS

- ENERGY STAR qualified.
- Complies with the CSA C22.2 no. 113 Standard.
- Complies with UL 507 requirements.

DIMENSIONS AND SERVICE CLEARANCE OF BROAN ESB10 SERIES RANGE HOOD

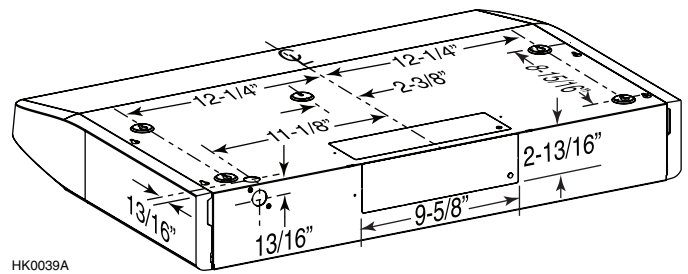
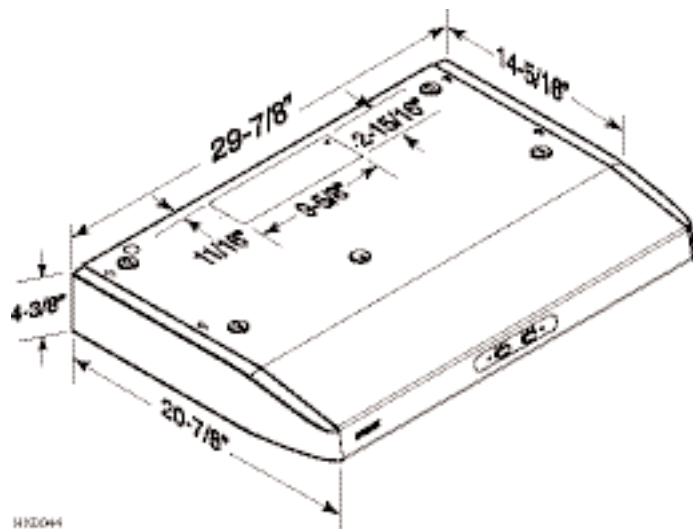

HK0039A

HK0044

VENTILATION PERFORMANCES

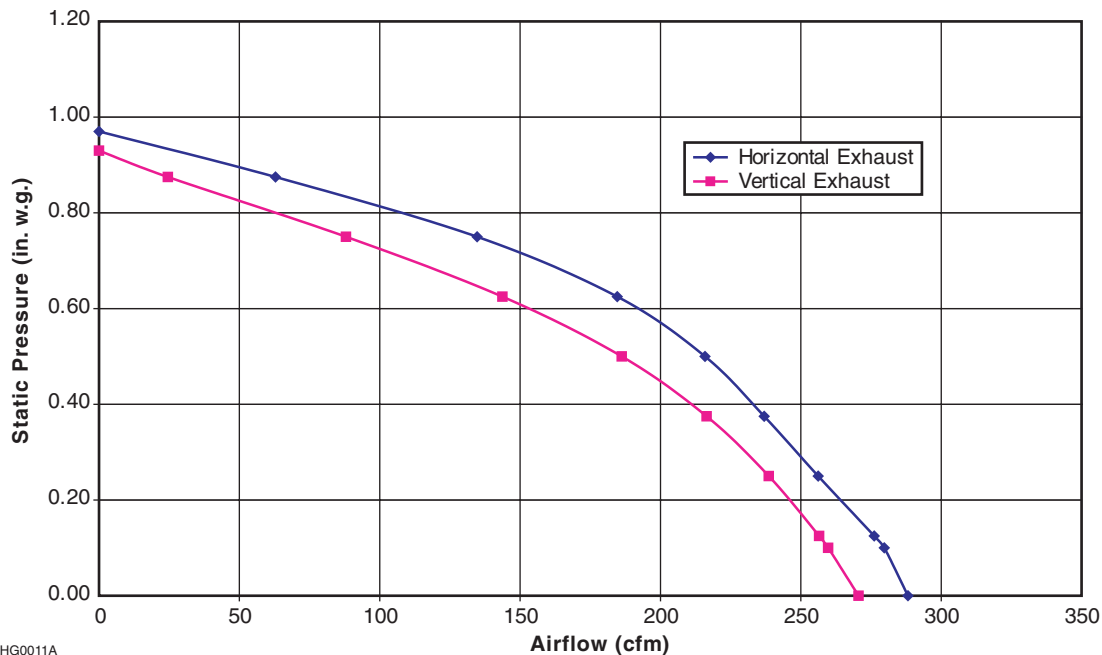

HG0011A

SPECIFICATION AND RATINGS

- Model: ESB10
- Part Numbers: ESB1030WH, ESB1030BL, and ESB1030SS
- Ducting: 3¼" x 10" or 6" round (transition 3¼" x 10" to 6" round not included)
- Vertical exhausting: 260 cfm
- Horizontal exhausting: 280 cfm
- Filters: Micromesh
- 0.9 sone at 100 cfm
- 5.5 sones at 280 cfm
- Power requirements: 120 V AC/60 Hz
- Total hood power consumption: 135 W
- Maximum amperage: 1.2 A
- Cabinet: 24 ga. pre-painted steel or stainless steel
- Lighting: 2 fluorescent lamps (13W, PLC13, 2700 K with G24q-1 base, included)
- Motor: Permanent Split Capacitor

Submitted by:		Date:	Project:
Quantity:	Model number:	Remarks:	Location:
			Architect:
			Engineer:
			Contractor:



BROAN

550 Lemire Blvd., Drummondville, Québec, Canada J2C 7W9 - Tel: 1 866 737-7770 Fax: 1 800 567-1715



01/08 PRODUCT SHEET NO. 91357A